

KIT RADIUS - CORNER GATE

Corner gate kit with galvanised steel accessories

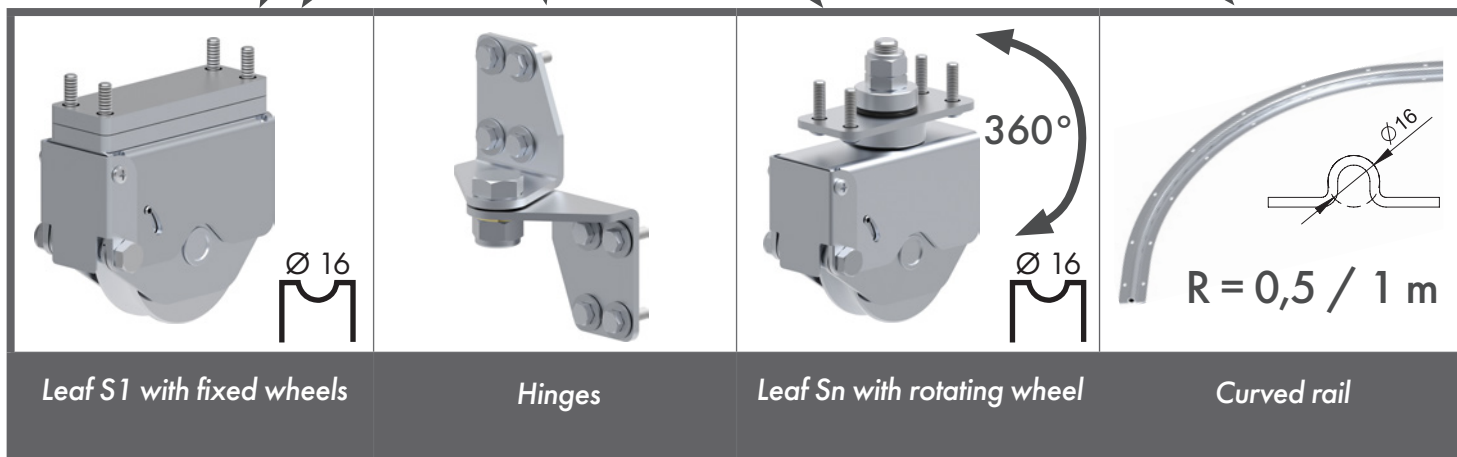

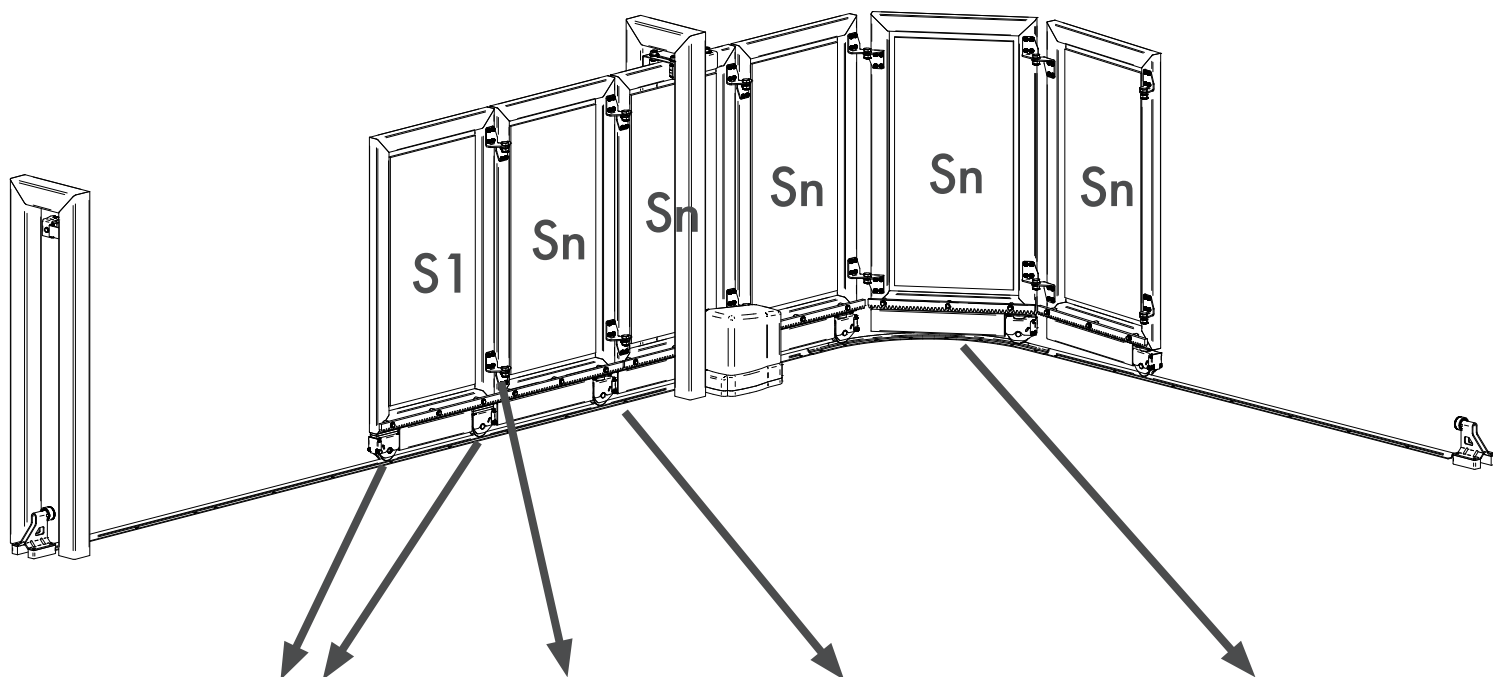



KIT MAIN LEAF S1

<p>KA8103.050</p>	<p>Curved rail R 0,50 m Leaves from 0,4 to 0,75 m</p>	 <p>R = 0,5m</p>
<p>KA8103.100</p>	<p>Curved rail R 1 m Leaves from 0,4 to 1,5 m</p>	 <p>R = 1m</p>

KA8103.001 KIT SECONDARY LEAF

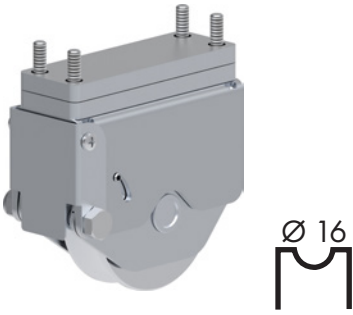
COMPONENT LIST

KA8103.050/.100 KIT MAIN LEAF S1

<p>x2</p>  <p>VA1321.075</p>	<p>x1</p>  <p>VA3205.B40</p>	<p>x2</p>  <p>VA4112.125</p>
<p>x1</p>  <p>VA2312</p>		

KA8103.001 KIT SECONDARY LEAF S_n

<p>x1</p>  <p>VA1322.075</p>	<p>x2</p>  <p>VL4600.135</p>	
---	---	--



RELATED ARTICLES

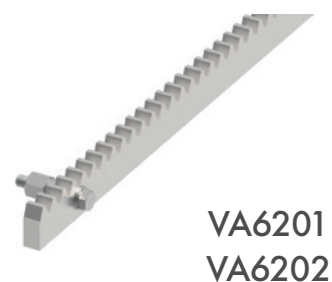



DIMENSIONING

LEAF WEIGHT	GATE WEIGHT	TUBULAR THICKNESS T
min 15 - max 100 Kg	500 Kg	min 40 - max 80 mm

S1 = Main Leaf = always 1 PIECE

Sn = Secondary leaves

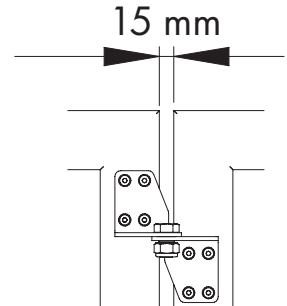
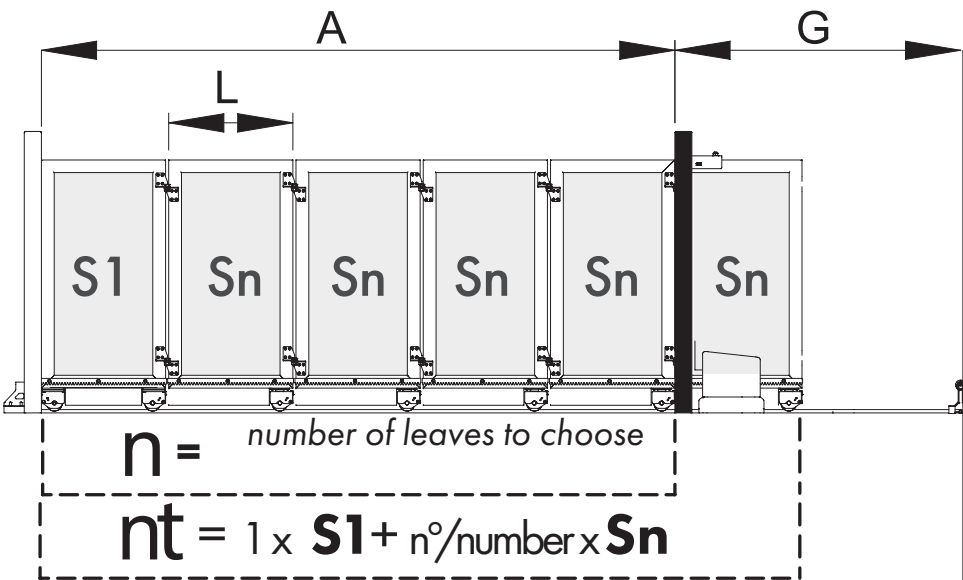

E min 0,35m/max = L

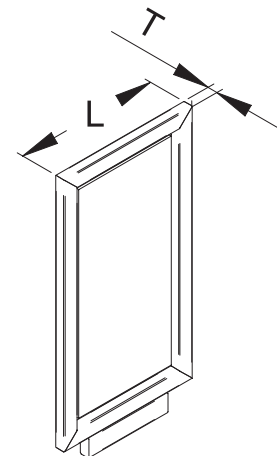
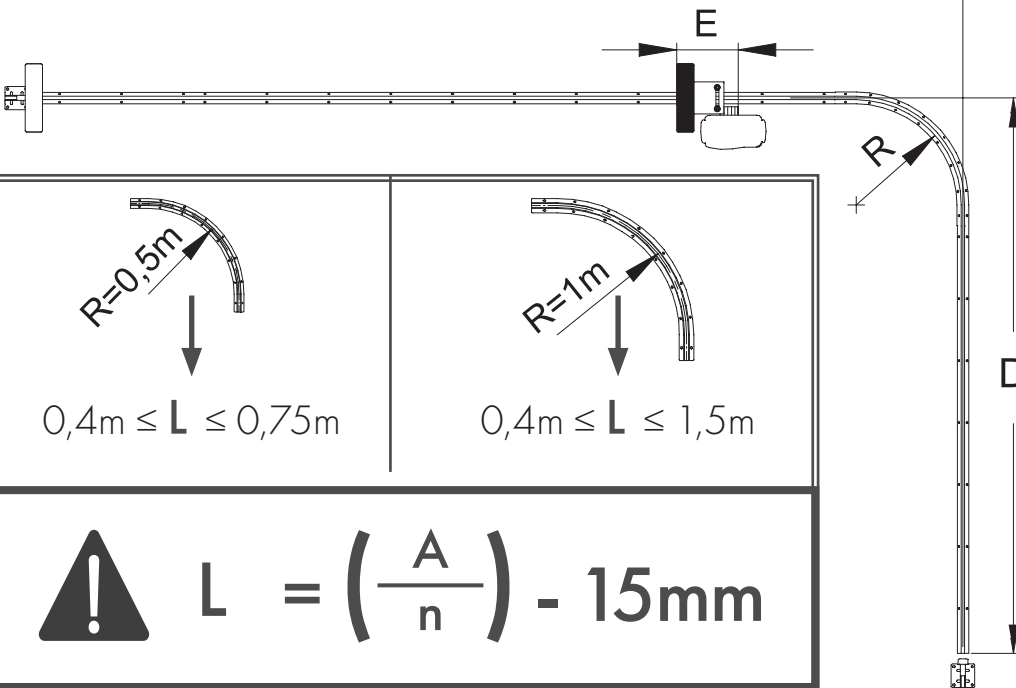
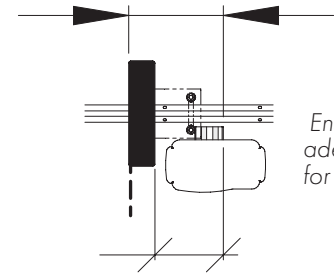

$G = L + E + R$

$D = A - E - 0,2 m$

$G = L + E + R$

$D = A - E - 0,4 m$



Warning:
 Raise or lower **n** to obtain compatible **L** values. Use short leaves and curved rails $R=0,5$ to obtain **G** values ($L \sim 0,4m$ e $E=0,35m$)
D depends on **A-L** values and on the radius **R** chosen

LEGENDA

- A** = opening
- G** = amount of space behind the opening
- E** = distance between the gate motor and column
- R** = radius of curve
- L** = leaf length
- D** = lateral space for the rail
- T** = leaf thickness
- nt** = total quantity of leaves

ITEMS TO ORDER TO REALISE YOUR GATE

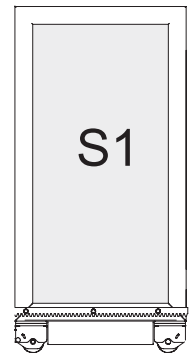
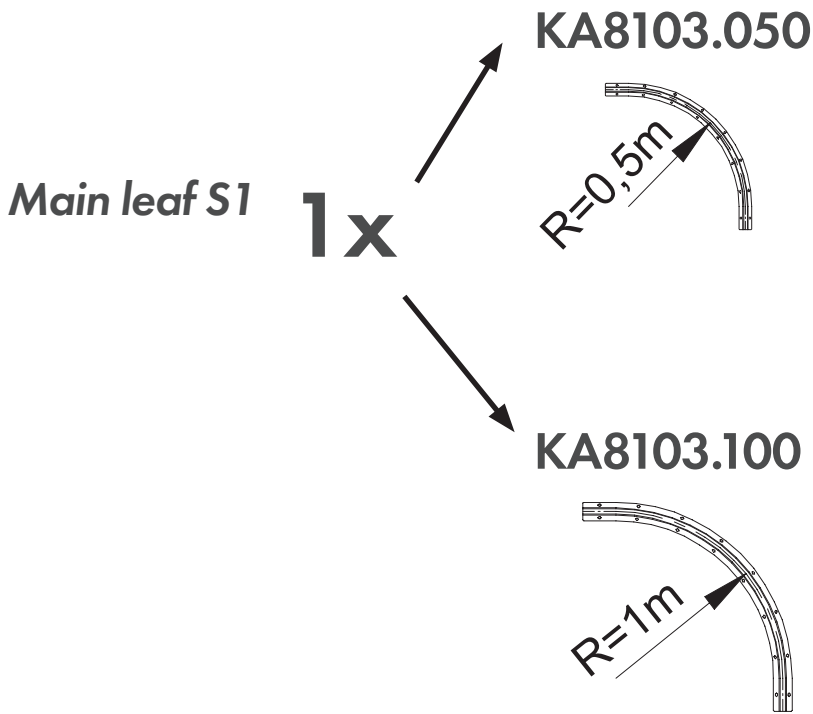

Secondary leaf **KA8103.001 x number of leaves Sn**

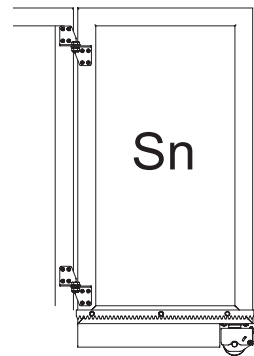



TECHNICAL INFO

1. Important: the gate working surface must be flat, without bumps or hollows
2. For motorised gates it is important to pay attention to the rack's cut, the positioning and the maximum measurements
3. For motorised gates provide slow starting points and soft stops, with a maximum speed of = 0,18 m/s

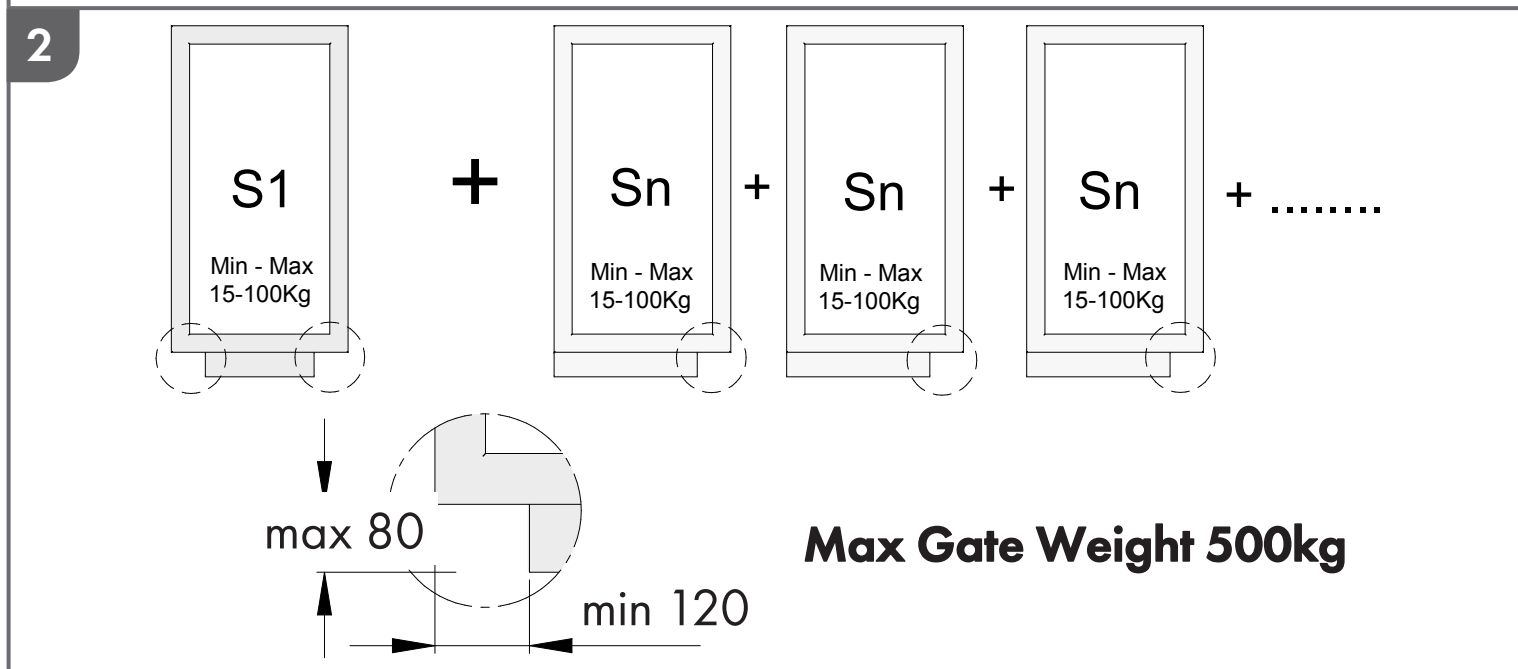
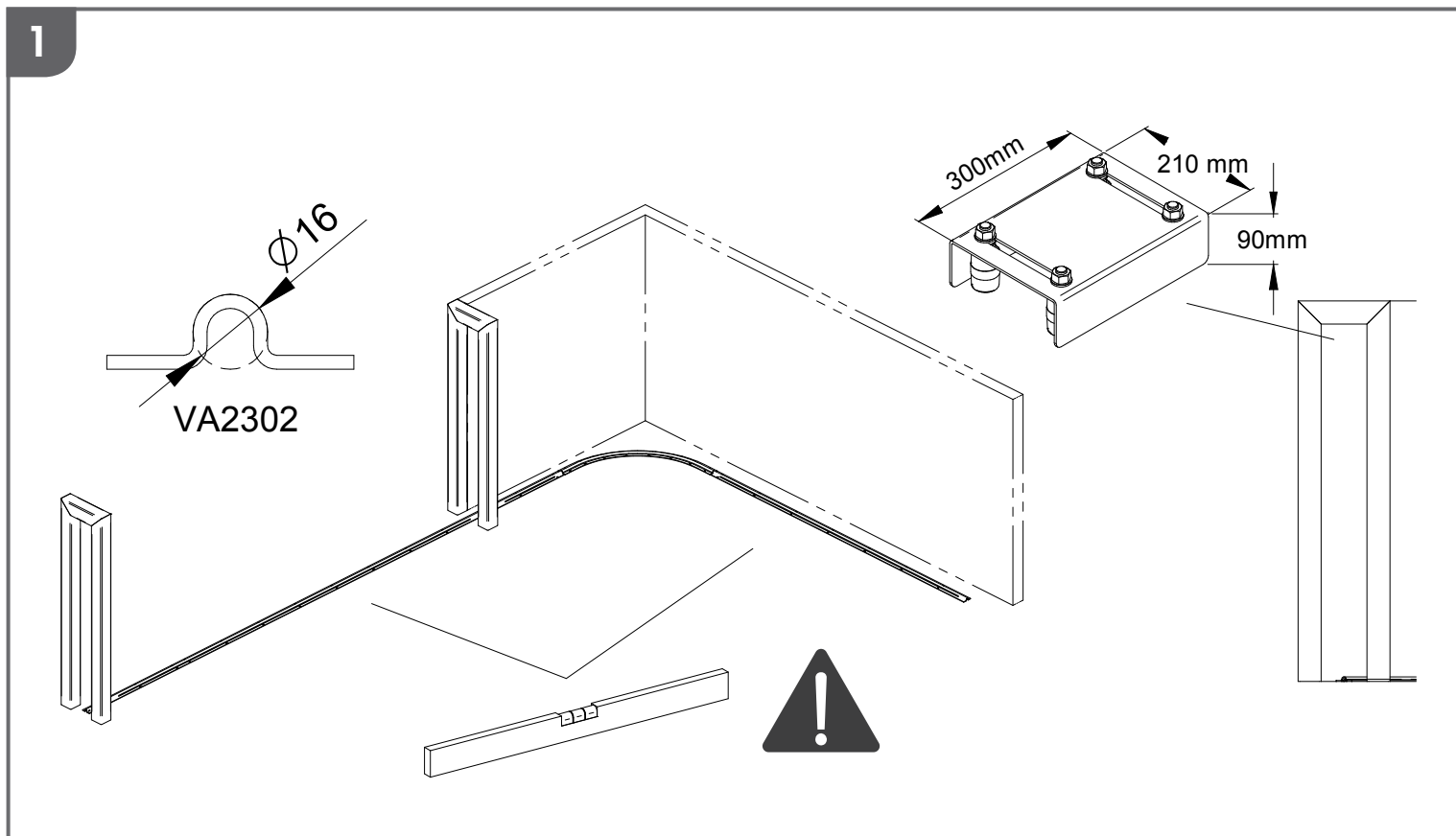

3

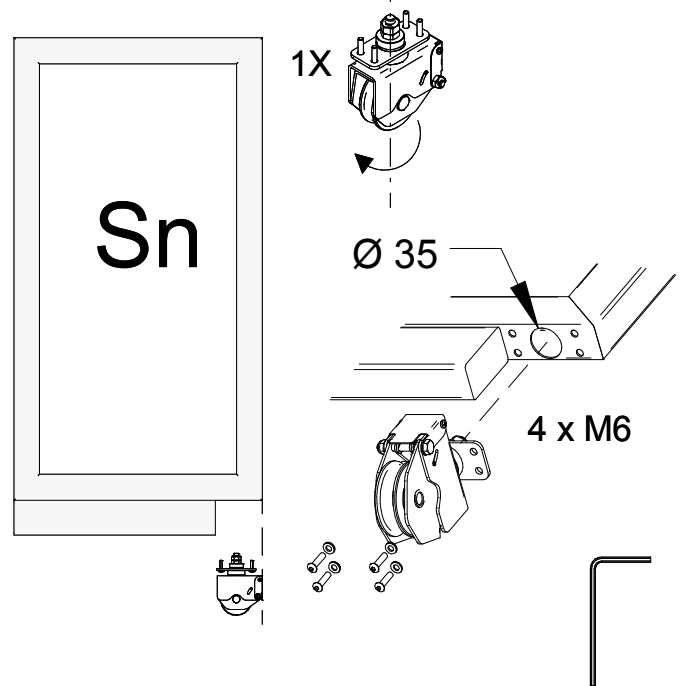
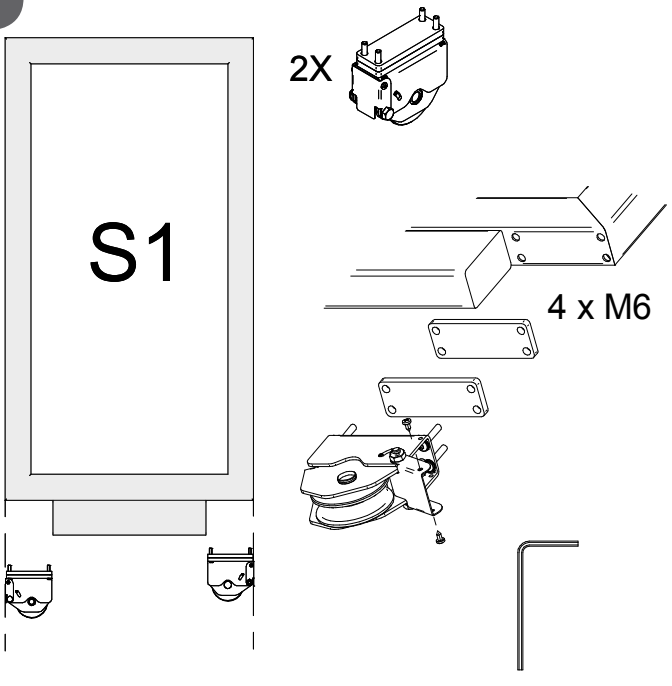

4

Rollers transition space required
H min 90mm

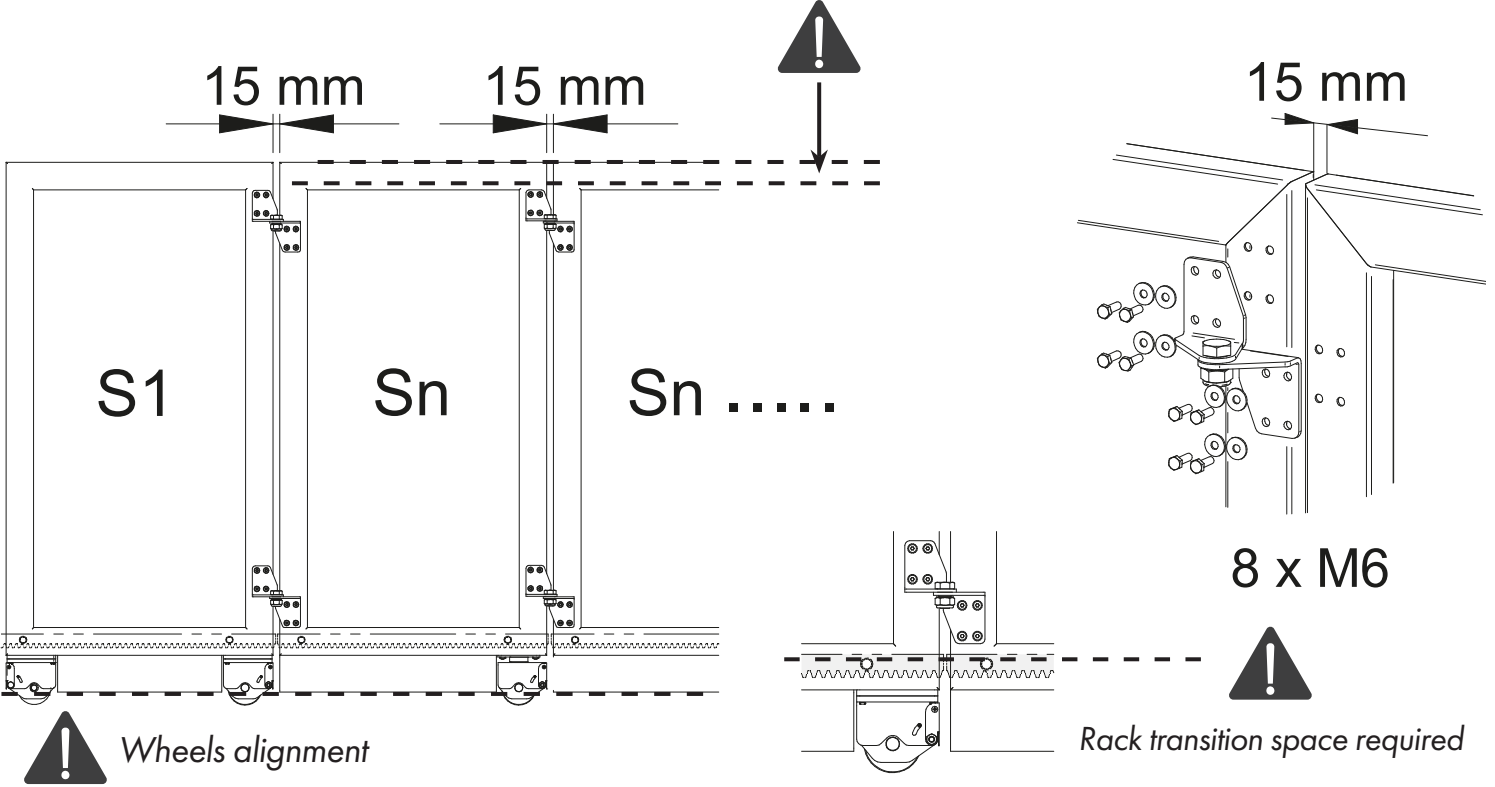

5

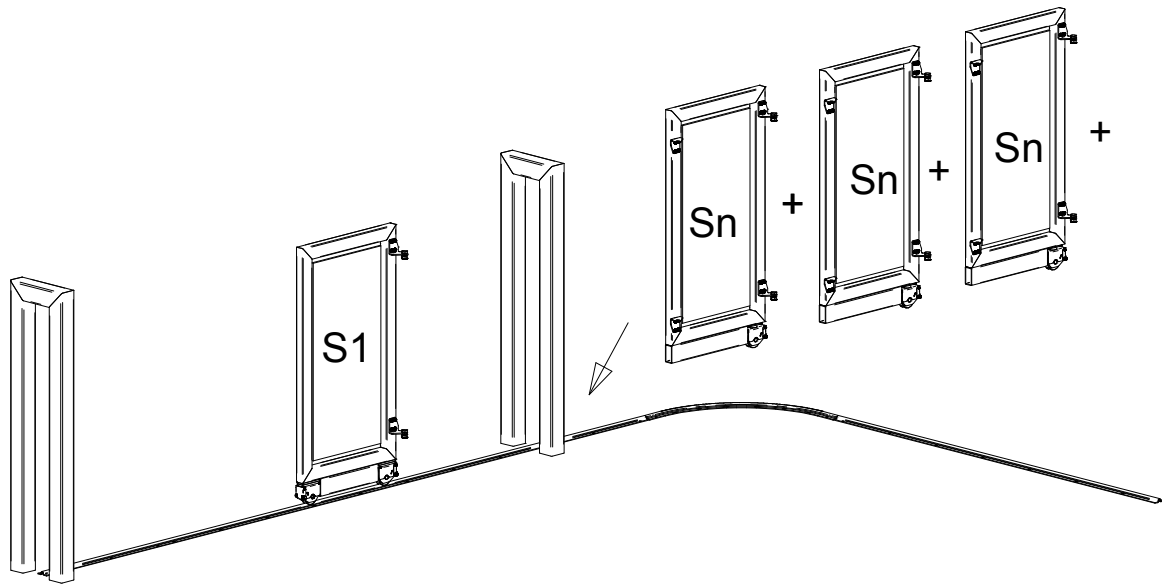

6

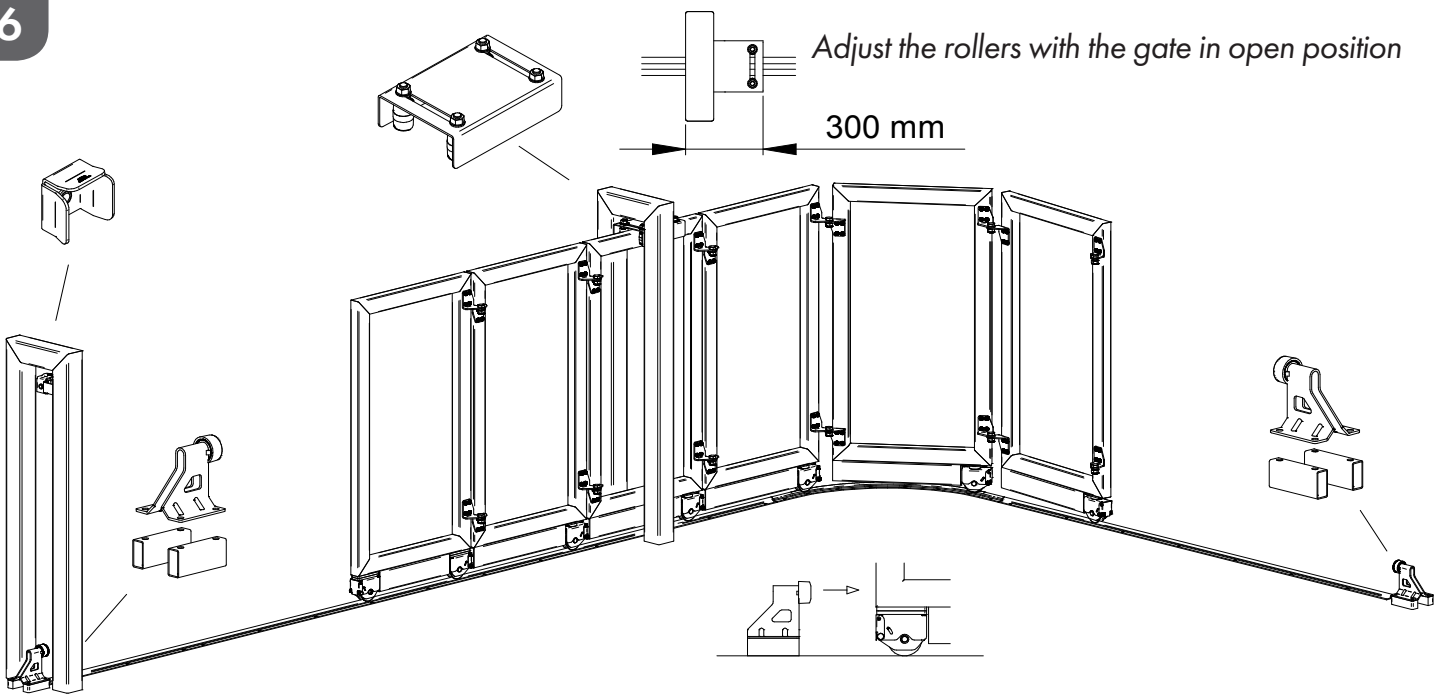

7

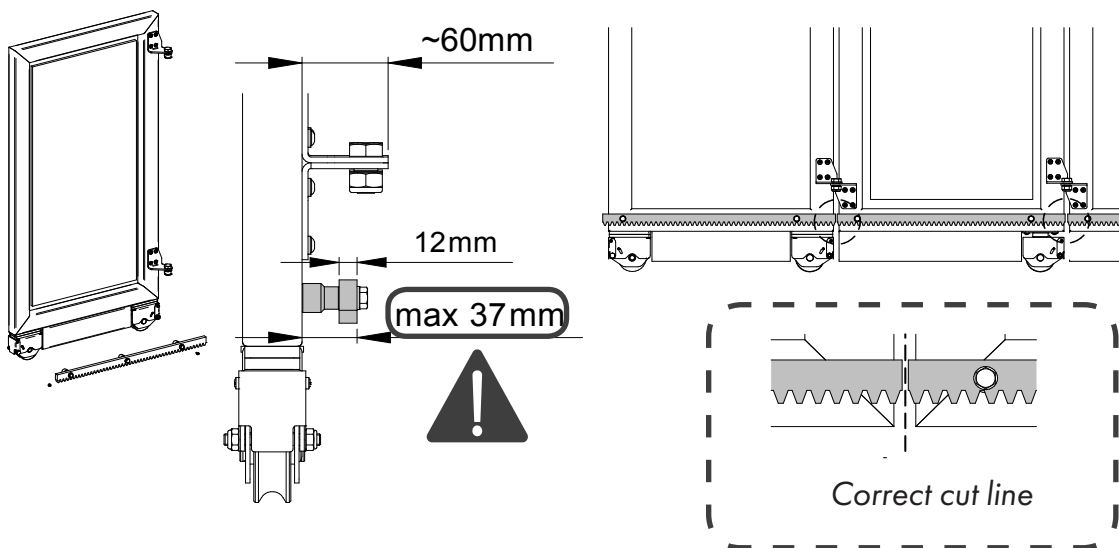



8



--- **Dangerous area**

Physical and electronic protections required

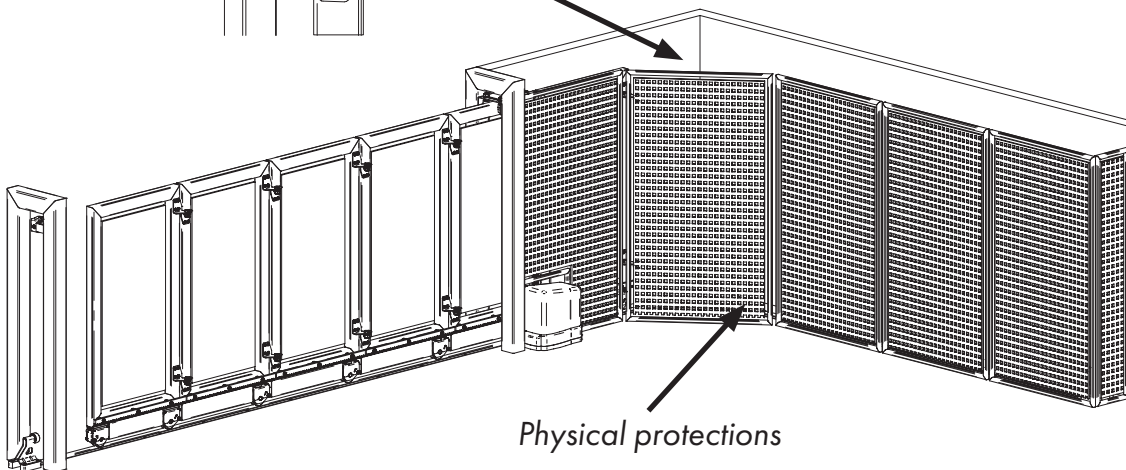
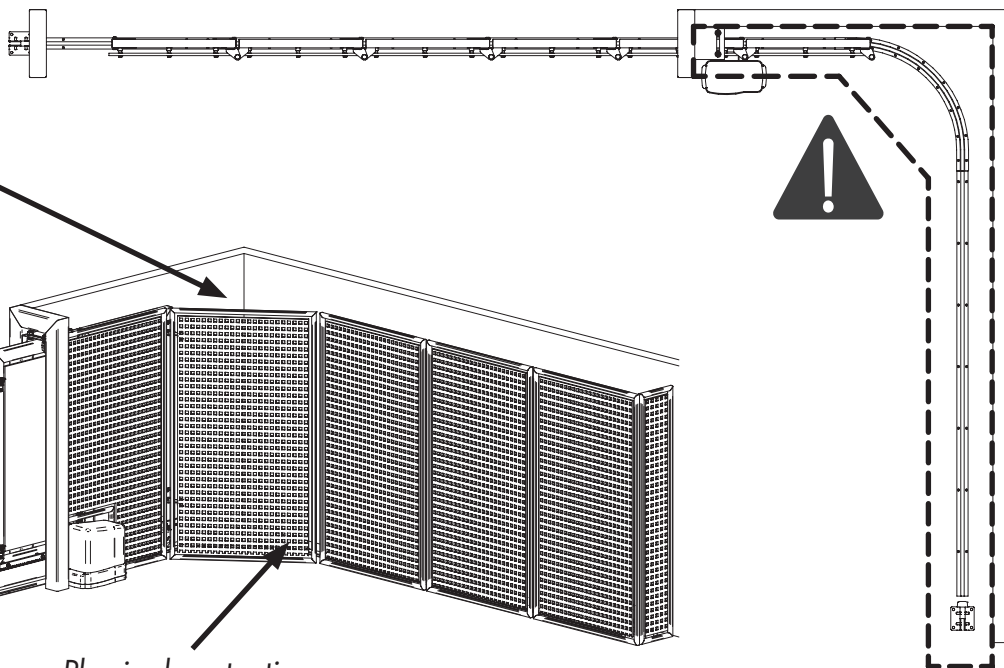
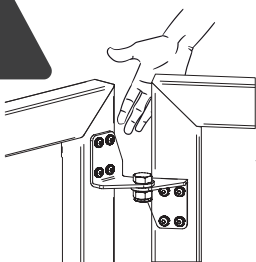

MAINTENANCE

1. Perform all functioning inspections manually at the end of the installation; periodically check that the system is functioning, well lubricated and does not have any loosening. (We suggest a full examination every 3 months or after 8000 cycles).
2. In case of malfunctions due to wear or accidental impacts, make sure that all components apt to support the gate and its maintenance are intact. If necessary, proceed with substitution.
3. FAC ensures the system correct functioning only using original spare parts.

Attention: The kit included accessories and the proposed installation make reference to a standard example. An installation not in accordance with the illustrated procedure and the omission of the correct maintenance might compromise nearby things and people's security. Make sure that all accessories suit the specific work and make sure to use the necessary safety devices provided by current regulations.

For more information: info@fac srl.com