



**ASSEMBLY GUIDE**



# DOUBLE SIDE WEDGE



## ORDER CONFORMITY

We advise you to read this manual completely and carefully before working on the equipment.

Using the delivery note, check the conformity of the delivery before any other intervention.

## ACTIVATE YOUR PRODUCT WARRANTY

Register directly on our website  
[www.sadev.com/maintenance-and-warranty](http://www.sadev.com/maintenance-and-warranty)



## Product description

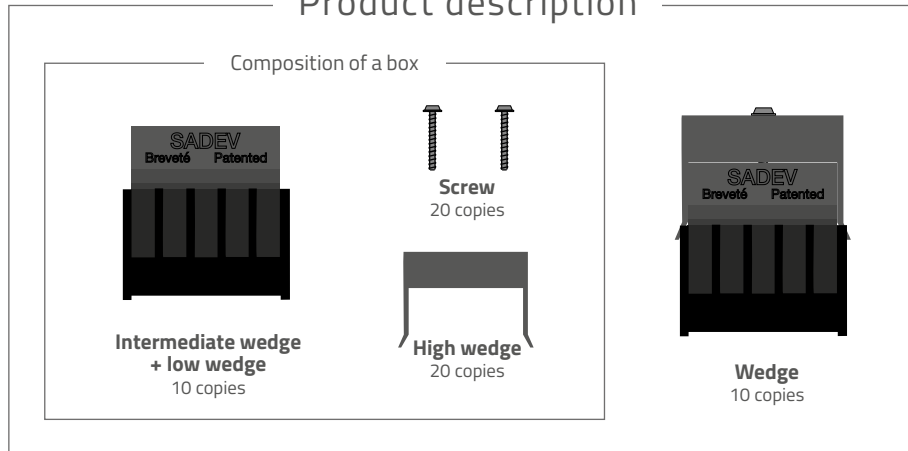

| Number on the wedge | Reference         | Glass composition | Glazing thickness [min.; max.] |
|---------------------|-------------------|-------------------|--------------------------------|
| 6                   | 0070KIT10CALE12   | 12-6.6            | 11.7 > 13.3                    |
| 5                   | 0070KIT10CALE15   | 15                | 14.5 > 15.5                    |
| 4                   | 0070KIT10CALE0808 | 8.8               | 16.2 > 18.2                    |
| 3                   | 0070KIT10CALE19   | 19                | 18.0 > 20.3                    |
| 2                   | 0070KIT10CALE1010 | 10.10             | 20.4 > 22.2                    |
| 1                   | 0070KIT10CALE1212 | 12.12             | 24.2 > 25.9                    |

### IMPORTANT



Control that the glass thickness is compatible with the wedges before installing it in the rail.

### GUIDELINES

The balustrade assembly must comply with these assembly instructions, as well as with the usual safety and usage precautions.

Any modification or degradation of SADEV's products disengage the responsibility of our company.



Available on [sadev.com](http://sadev.com)

## SUMMARY

|   |    |
|---|----|
| <b>A</b> RAIL FIXING .....                        | 8  |
| <b>B</b> PROFILE CONNECTION .....                 | 11 |
| <b>C</b> WEDGES ASSEMBLY .....                    | 12 |
| <b>D</b> GLASS INSTALLATION AND ADJUSTMENT .....  | 13 |
| <b>E</b> GLASS SPACING .....                      | 14 |
| <b>F</b> INSTALLATION OF HIGH WEDGES .....        | 15 |
| <b>G</b> WEDGES TIGHTENING .....                  | 16 |
| <b>H</b> INSTALLATION OF THE CLADDING .....       | 17 |
| <b>I</b> PRESS-IN GASKET ASSEMBLY .....           | 19 |
| <b>J</b> INSTALLATION OF THE END CAP .....        | 20 |
| <b>K</b> REMOVING WEDGES <b>MAINTENANCE</b> ..... | 21 |

## Tools required for assembly

- **ROTARY HAMMER**
- **CORDLESS DRIVER**
- **TIGHTENING TOOL AND TORQUE CONTROL** according to the type of dowel used
- **DYNAMOMETRIC SCREWDRIVER PACK + TORX BIT**  
Ref.: 007-TRVS-2 NM - Tightening torque: 2 Nm
- **LEVEL TOOL**
- **SADEV CLEANING SET** - Ref.: 70UT-KITNET
- **SADEV SET OF SHIMS** (different references depending on the profile).

## HOW TO MADE A WATER DRAINAGE

Water drainage in the SABCO quadrail is carried out by drilling the alluminium rail and/or the finishing plugs according to the technical drawings below.

As the rail must be laid straight (without deformation), the water drains off naturally on both sides of it. Depending on the situation,  $\varnothing 8$ mm holes can be drilled on site in the plug and/or profile for water drainage.

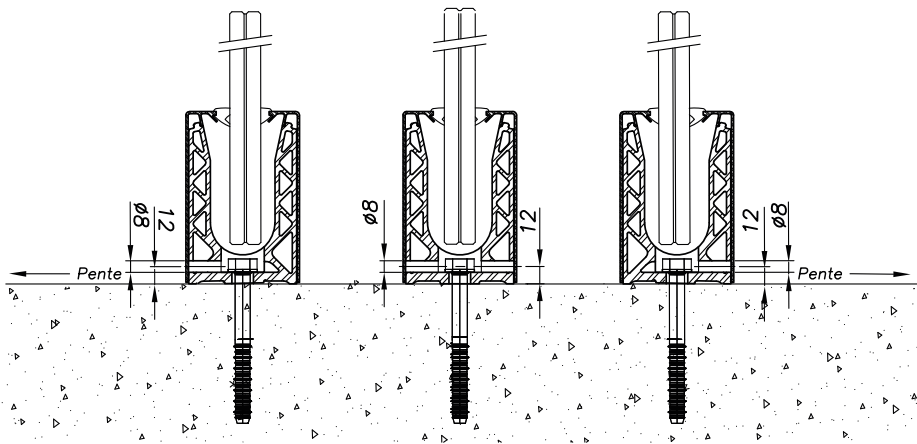

7010 / 7030

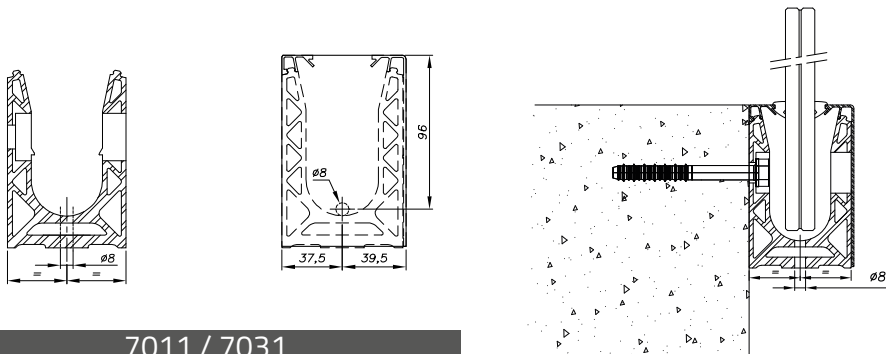

7011 / 7031

## HOW TO MADE A WATER DRAINAGE

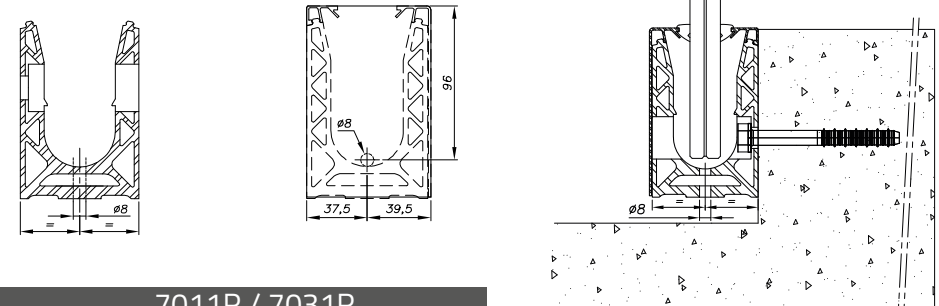

7011R / 7031R

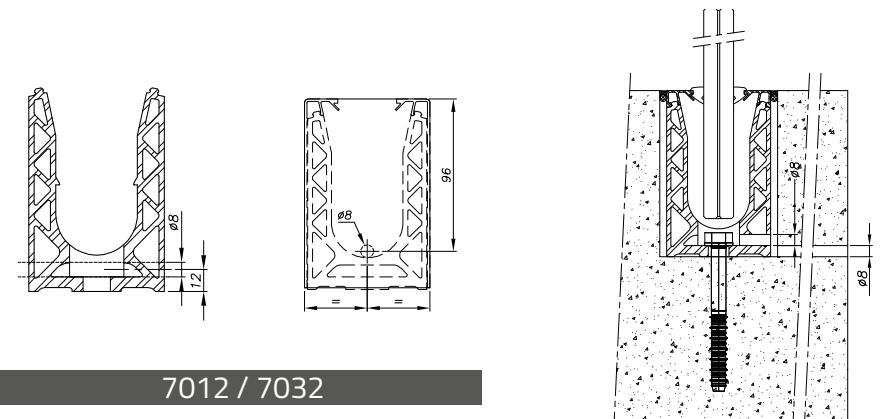

7012 / 7032

## HOW TO MADE A WATER DRAINAGE

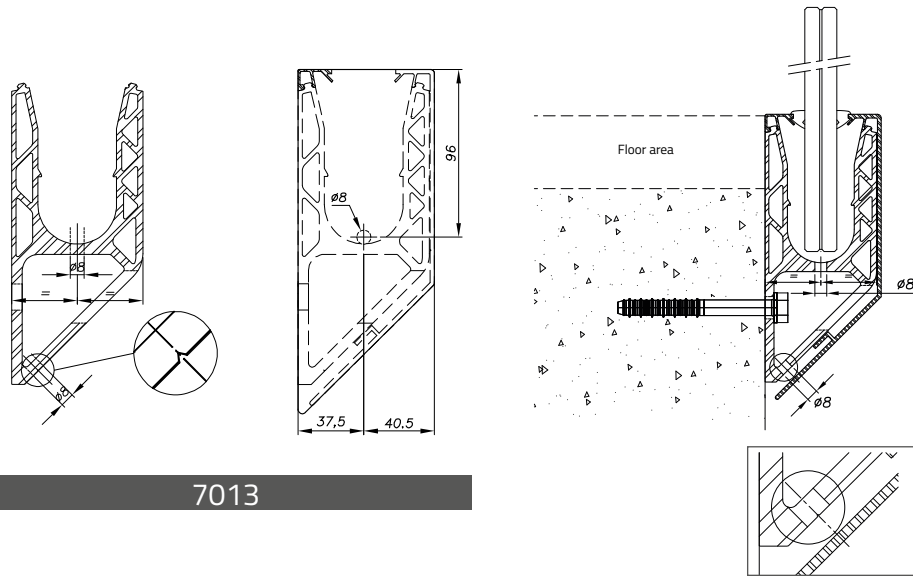

7013

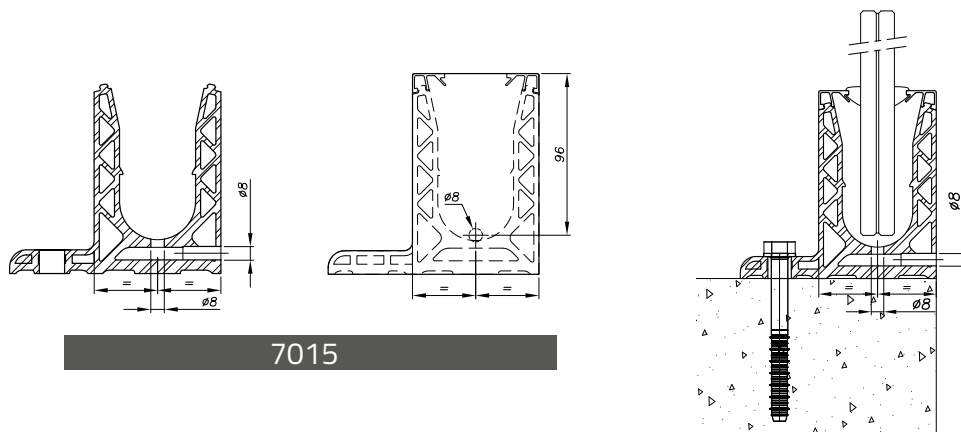

7015

## RAIL AND CLADDING EXPANSION INFORMATIONS



**Expansion is taken into account to ensure that the rails and claddings are held securely in place. The building's expansion gasket must be respected in the balustrade assembly.**

During the balustrade assembly, **you must consider the coefficient of thermal expansion.**

### What does it refer?

The coefficient of thermal expansion is the expansion at constant pressure of the railing caused by its heating or cooling.

|                                     |       | ALUMINIUM                   |       |       |       |       |
|-------------------------------------|-------|-----------------------------|-------|-------|-------|-------|
| 2 500mm                             |       | Maximum profile temperature |       |       |       |       |
| Profile temperature during assembly |       | 104°F                       | 122°F | 140°F | 158°F | 176°F |
|                                     | -4°F  | 4mm                         | 4mm   | 5mm   | 5mm   | 6mm   |
|                                     | -14°F | 3mm                         | 4mm   | 4mm   | 5mm   | 5mm   |
|                                     | 32°F  | 3mm                         | 3mm   | 4mm   | 4mm   | 5mm   |
|                                     | 50°F  | 2mm                         | 3mm   | 3mm   | 4mm   | 4mm   |
|                                     | 68°F  | 1mm                         | 2mm   | 3mm   | 3mm   | 4mm   |
| 86°F                                | 1mm   | 1mm                         | 2mm   | 3mm   | 3mm   |       |

|                                     |       | ALUMINIUM                   |       |       |       |       |
|-------------------------------------|-------|-----------------------------|-------|-------|-------|-------|
| 5 000mm                             |       | Maximum profile temperature |       |       |       |       |
| Profile temperature during assembly |       | 104°F                       | 122°F | 140°F | 158°F | 176°F |
|                                     | -4°F  | 7mm                         | 8mm   | 9mm   | 11mm  | 12mm  |
|                                     | -14°F | 6mm                         | 7mm   | 8mm   | 9mm   | 11mm  |
|                                     | 32°F  | 5mm                         | 6mm   | 7mm   | 8mm   | 9mm   |
|                                     | 50°F  | 4mm                         | 5mm   | 6mm   | 7mm   | 8mm   |
|                                     | 68°F  | 3mm                         | 4mm   | 5mm   | 6mm   | 7mm   |
| 86°F                                | 1mm   | 3mm                         | 4mm   | 5mm   | 6mm   |       |

## A RAIL FIXING

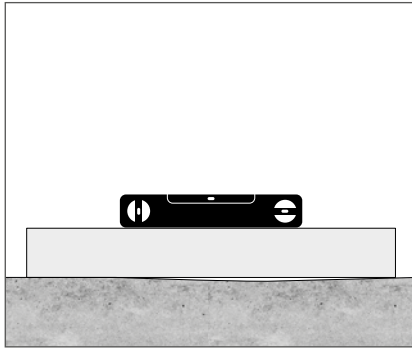

1 - Check the flatness and conformity of the support with a ruler.

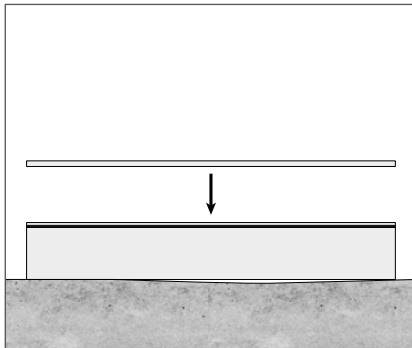

2 - Level with the help of the closing cladding ref: 0070CAPO221

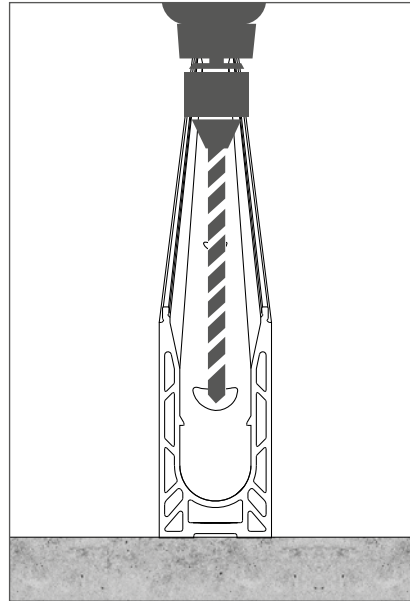

3 - Drill the support with a tool adapted to it.

## A RAIL FIXING

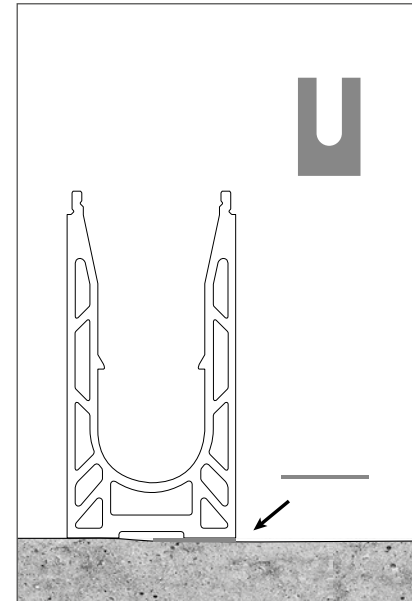

4 - If the support is uneven, level the profile by adding our SADEV wedge set. These wedges must be placed at the level of the fasteners (it is possible to put several of them).

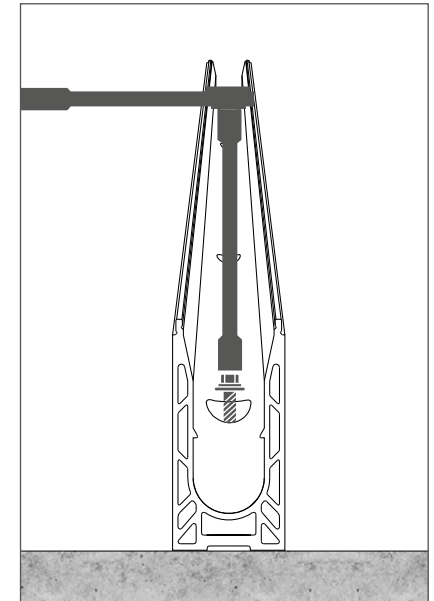

5 - Adjust and fix the rail with the appropriate wrench to the fixing pins. Respect the tightening torque and the mounting recommendations recommended by the manufacturer.

### INFORMATIONS

Possible supports: concrete, wood, metal, others...

The support must be able to support the loads induced by the balustrade.

## A RAIL FIXING

### LATERAL MOUNTING

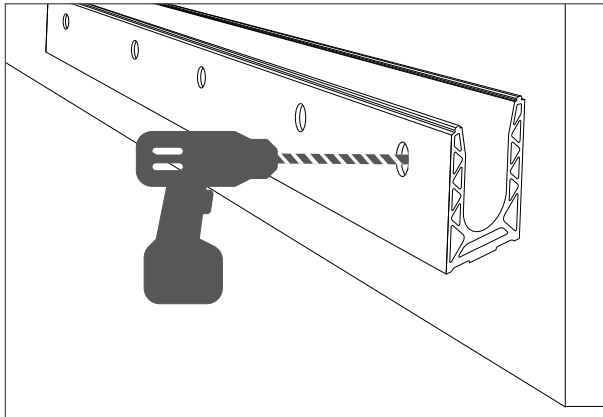

- 1 - Drill the support with a tool adapted to it.
- 2 - If the support is irregular, level the profile by adding our SADEV wedge set. These wedges must be placed at the level of the fasteners (it is possible to put several of them).

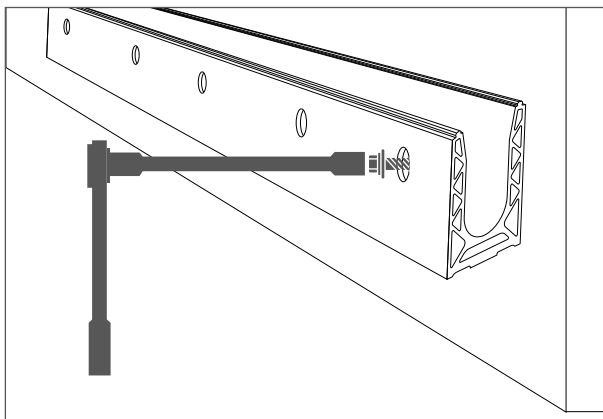

- 3 - Adjust and fix the rail with the appropriate wrench to the fixing pins. Respect the tightening torque and the mounting recommendations recommended by the manufacturer.

## B PROFILE CONNECTION

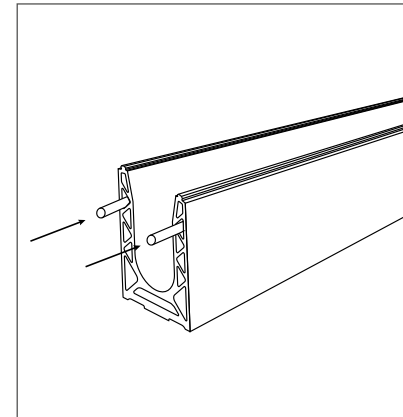

- 1 - Fit 2 SADEV pins connector in the rail section holes.

### Location of spring pins

007Goup-  
EVO-14-40

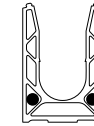

7030  
7031  
7032

D1481A1-08-50

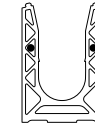

7010  
7011  
7011R  
7012

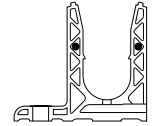

7015



7013

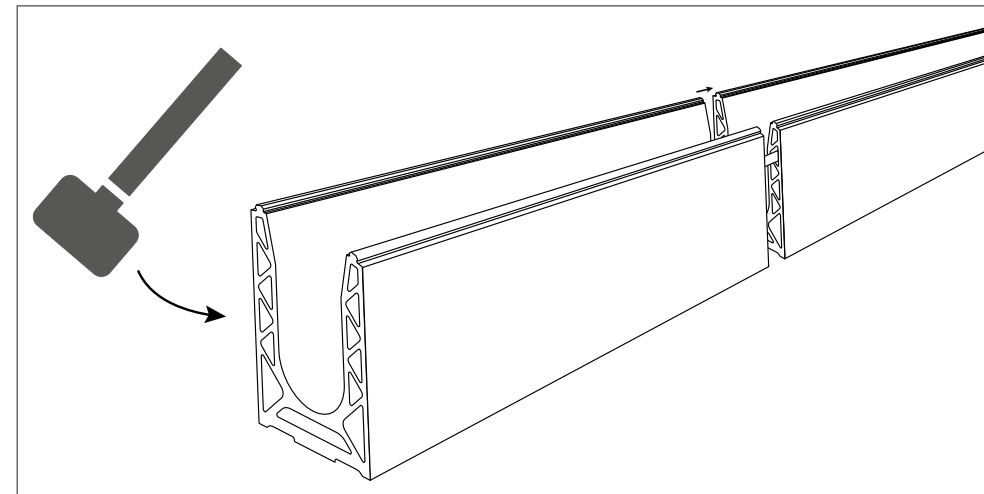

- 2 - Connect the rails together by using a mallet.

## C WEDGES ASSEMBLY

**Standard configuration for a 2.5 meter rail: 10 wedges (1 box)**

Example: 3 wedges / linear meter even when the width of the glass is < 1 meter.

⚠ Refer to the technical notice for other configurations.

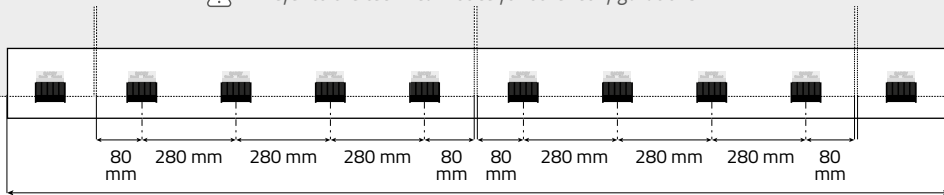

Rail length: 2 500mm

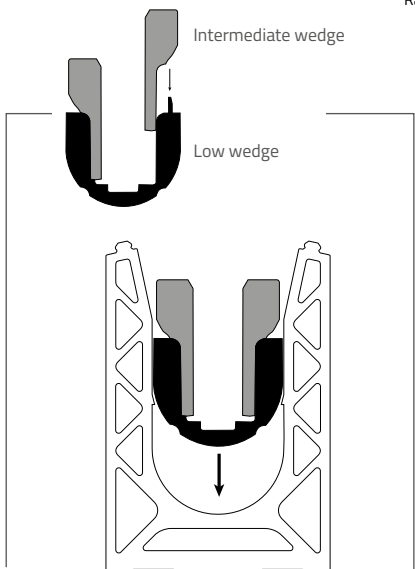

⚠ Before positioning the wedges in the rail, make sure that the intermediate wedges are properly inserted on the bottom wedges.

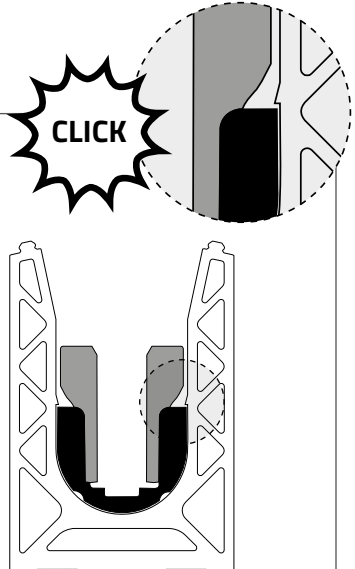

⚠ The wedges must be correctly positioned, you should hear «click» when you insert them.

- 1 - Cleaning the rail with the Sadev cleaning set. Ref. : 7OUT-KITNET
- 2 - Install the wedge in the rail.

## D GLASS INSTALLATION AND ADJUSTMENT

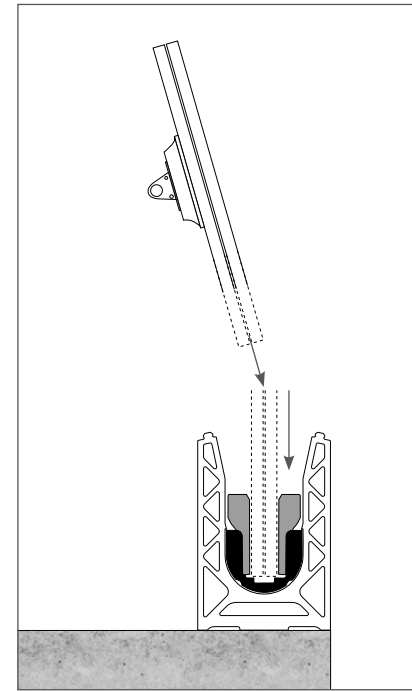

1 - Lift the glass inside the wedges.

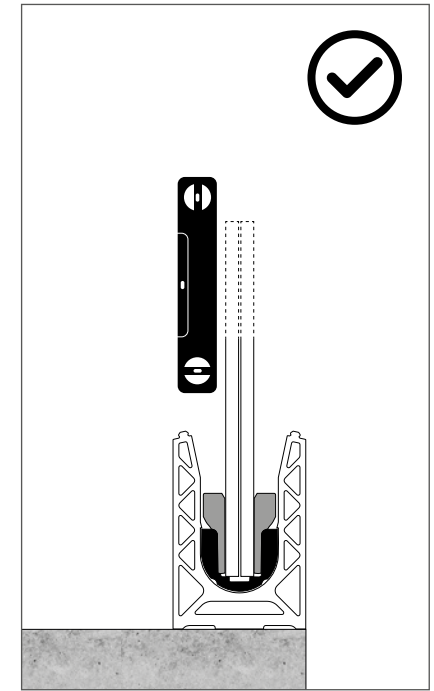

2 - Level the glass before adding the high wedge.

## E GLASS SPACING

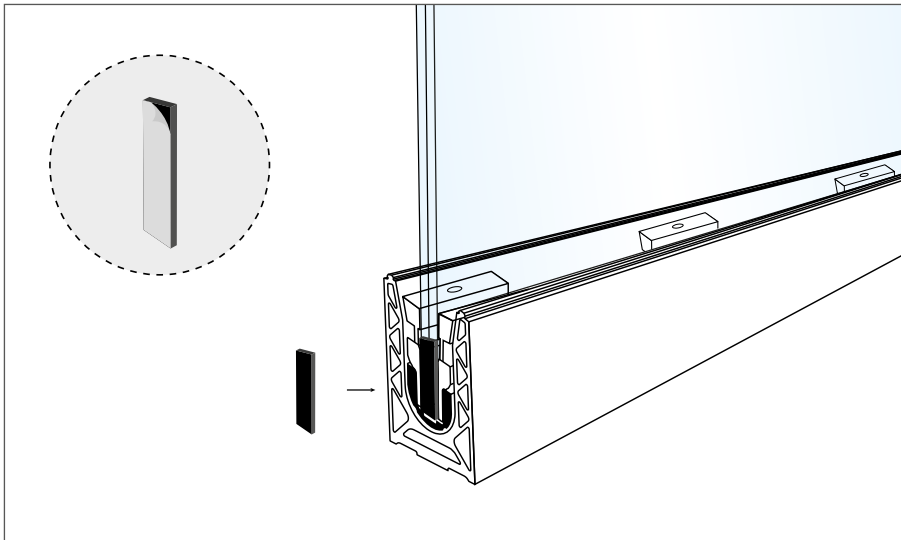

1 - Remove the protection from the adhesive. Stick the SADEV spacer on the edge of the glass, on the bottom right-hand corner flush with the glass.

The spacers have different functions:

- To have a regular space between the glass panels.

The spacers are 5 mm wide. If you need a larger gap, you can stick the spacers together to obtain spacings of 10, 15 mm...

## F INSTALLATION OF HIGH WEDGES

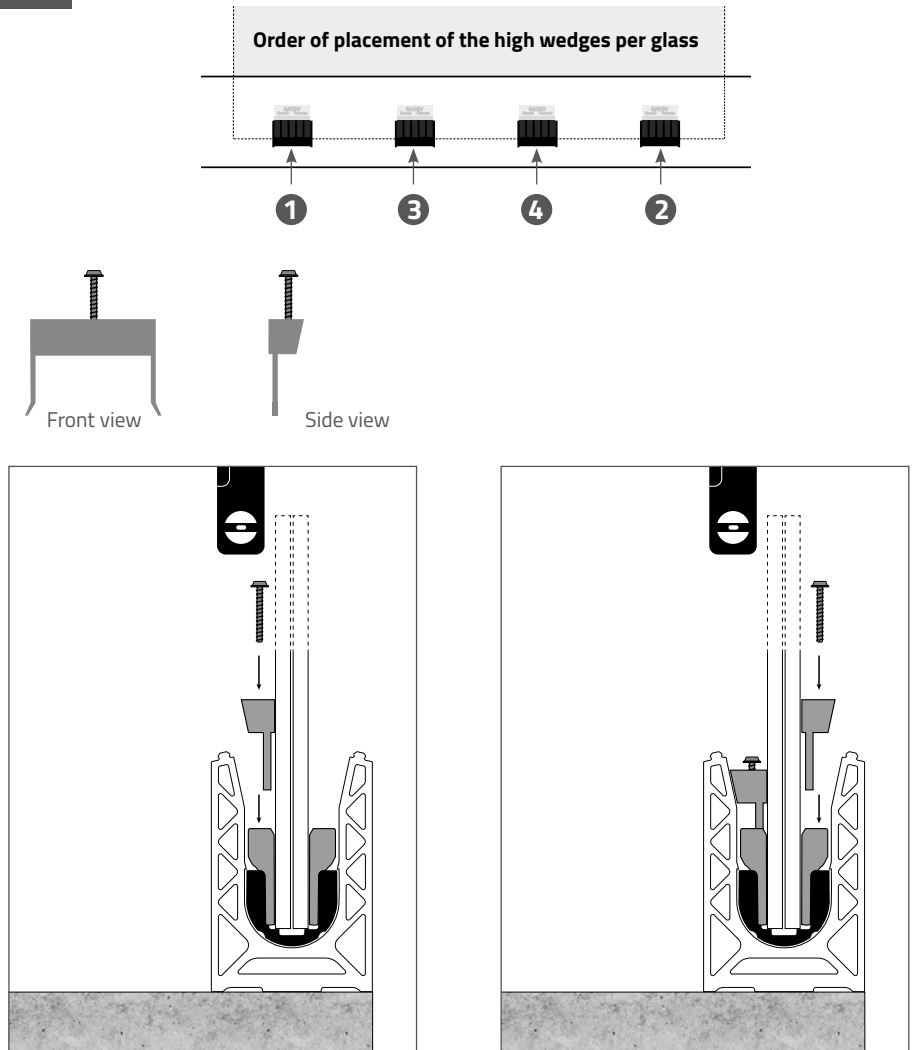

1 - Insert the high wedge while maintaining the level of the glass



## G WEDGES TIGHTENING

Use the torque screwdriver for torque control: 2 Nm

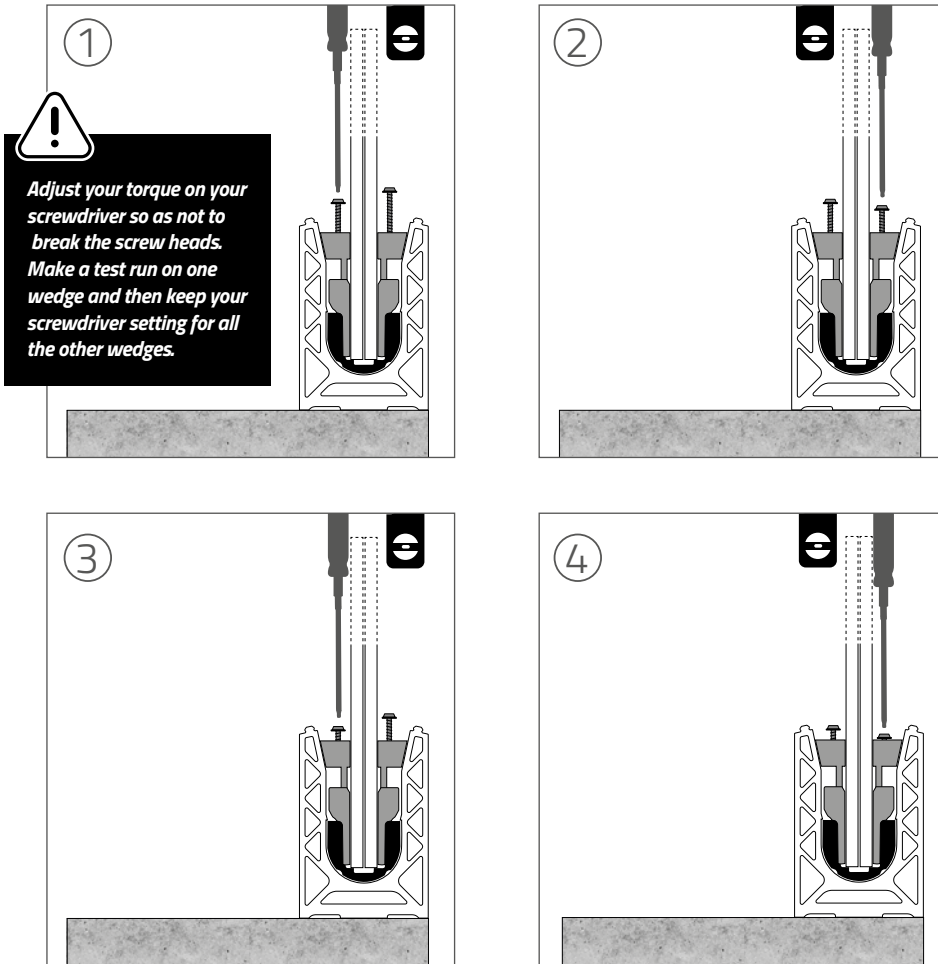

2 - Screw on each side of the glass as long as you do not change the level of the glass.

## H INSTALLATION OF CLADDING



The adhesive application at below 10 °C is not recommended.

### Floor mounting

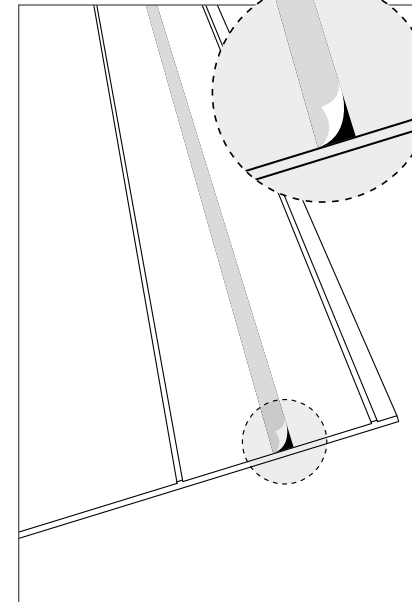

- 1 - Cleaning the rail with the Sadev cleaning set. Ref. : 70UT-KITNET before the installation of the accessible side cladding
- 2 - Remove the adhesive protection.



It is advisable to align the junctions of the claddings with those of the rails.

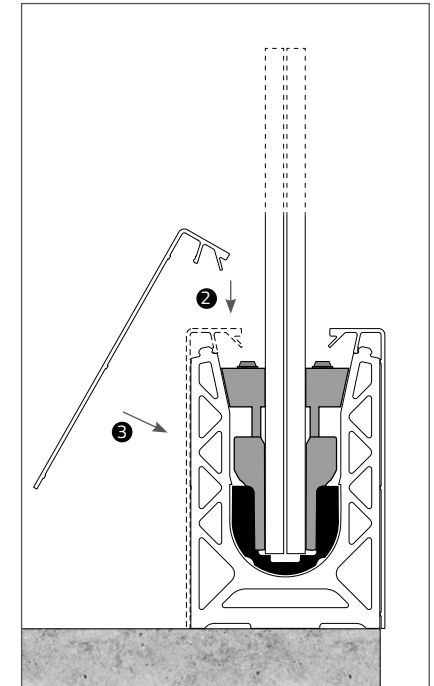

- 1 - Clip the top of the cladding.
- 2 - Press the cladding on the rail.

Other cladding configuration possible:

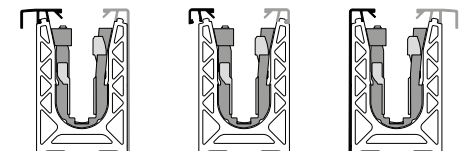

## H INSTALLATION OF CLADDING

### Offset mounting

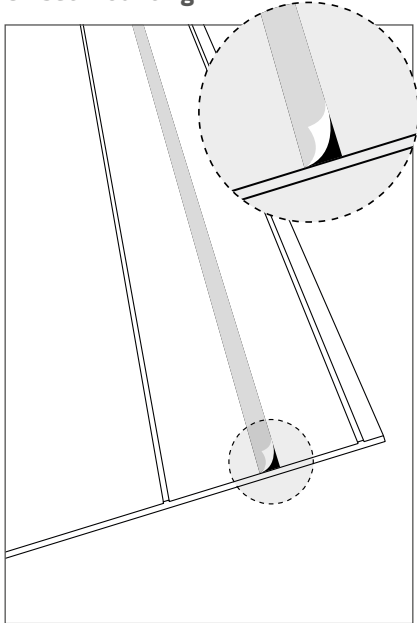

- 1 - Cleaning the rail with the Sadev cleaning set. Ref. : 70UT-KITNET before the installation of the accessible side cladding
- 2 - Remove the adhesive protection.

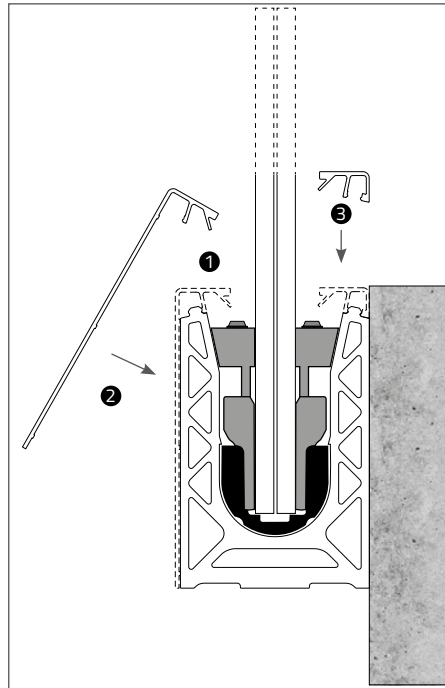

### High cladding

- 1 - Clip the top of the cladding.
- 2 - Press the cladding on the rail.

### Small cladding

- 3 - Clip the small cladding on the side of the slab for slab nose applications (007011 - 007013).

## I PRESS-IN GASKET ASSEMBLY

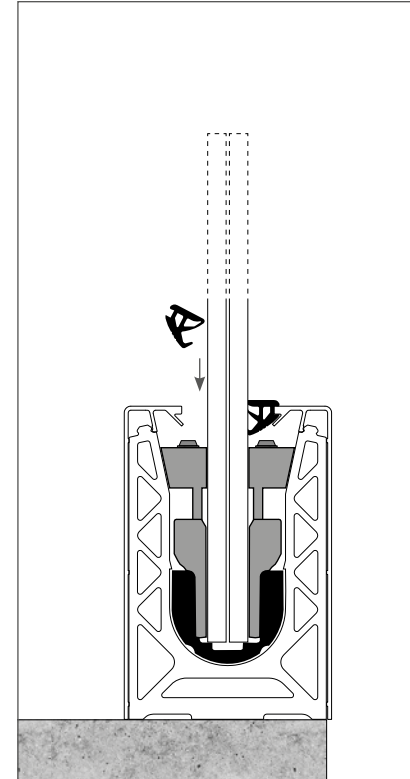

- 1 - Add the press-in gasket between the cladding and the glass.

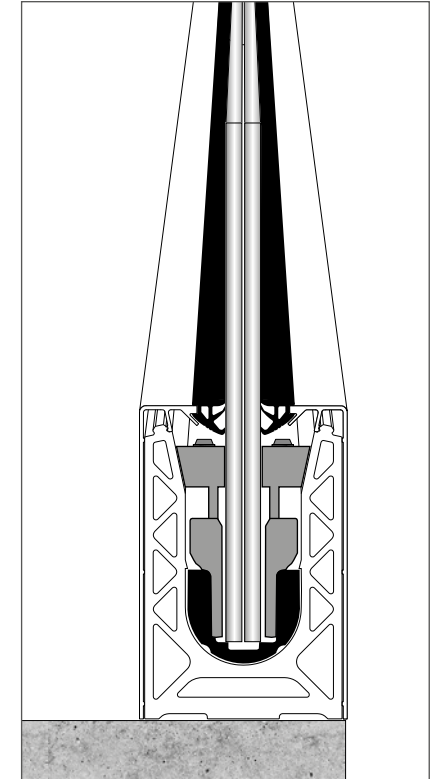

- 2 - Do not stretch the gasket by clipping it.



**The gasket must be correctly installed along the entire length of the cladding.**

## J INSTALLATION OF END CAPS

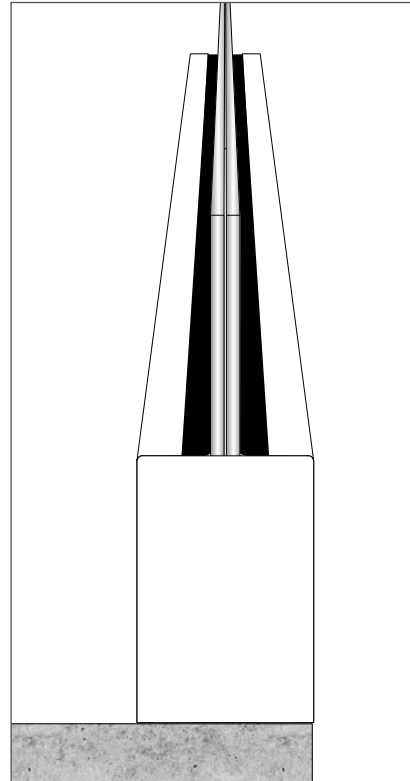
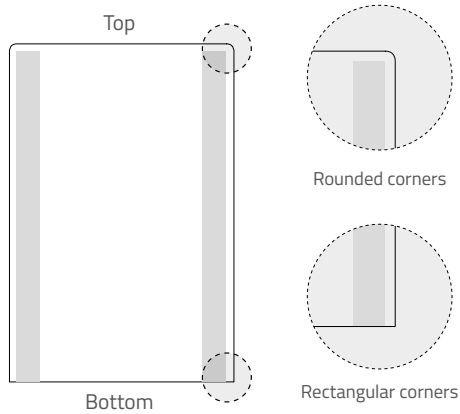

- 1 - Cleaning the rail with the Sadev cleaning set. Ref. : 70UT-KITNET before installing the end cap.
- 2 - Remove the adhesive protection.
- 3 - Press the end cap at the end of the rail.

**You have successfully assembled your balustrade!**

## K REMOVING WEDGES MAINTENANCE

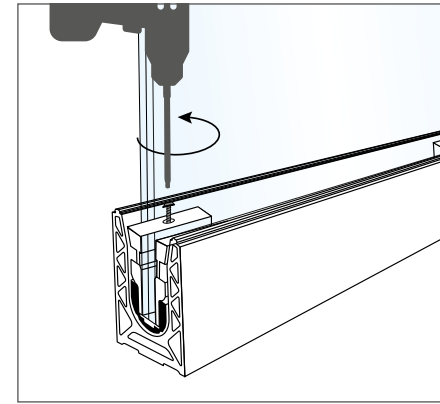

- 1 - After removing the cladding and gasket, unscrew the screws 1 cm high.

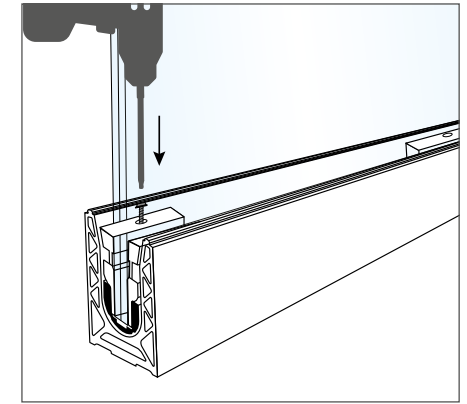

- 2 - Apply a force on the screw in order to lower the intermediate wedge.

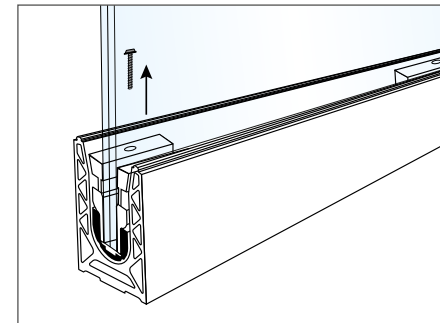

- 3 - Finish unscrewing the screw and remove it

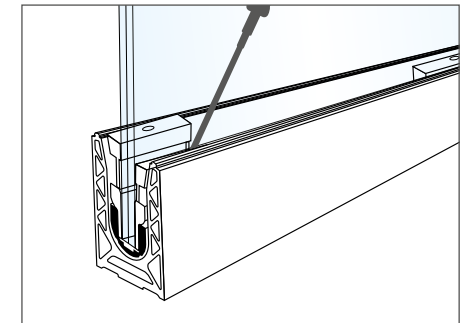

- 4 - Using a screwdriver, pry between the intermediate and upper wedge to remove the high wedge.

### INFORMATIONS

Once all the high wedges have been removed from the rail, remove the glass.  
**Replace all wedges. The wedges cannot be reused.**



Notes

.....

.....

.....

.....

.....

.....

.....

.....

.....

.....

.....

.....

.....

.....

.....

.....

.....

.....

.....

.....

.....

.....

Notes

.....

.....

.....

.....

.....

.....

.....

.....

.....

.....

.....

.....

.....

.....

.....

.....

.....

.....

.....

.....

.....



## ASSEMBLY GUIDE DOUBLE SIDE WEDGE

Disponible sur [sadev.com](https://www.sadev.com) 



76 Chemin des Poses | 74330 POISY | FRANCE |  
Tél. : +33 (0)4 50 08 39 00 | [info@sadev.com](mailto:info@sadev.com) | [www.sadev.com](http://www.sadev.com)