

Hatch glass

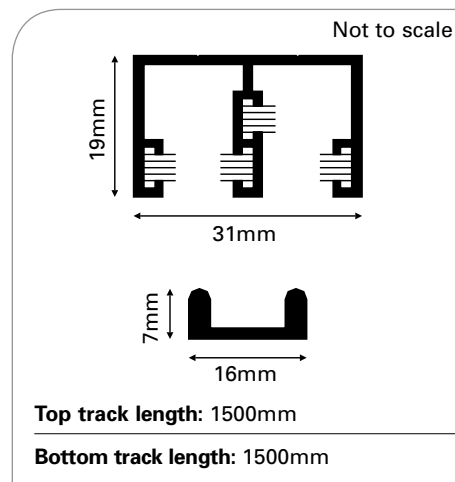

Number of doors	2
Maximum door weight	20 kg
Maximum door width <small>(excludes overlap)</small>	750 mm
Maximum opening width	1500 mm
Maximum door height	1000 mm
Glass thickness	6 mm

Bottom rolling, bi-passing, sliding system for a pair of glass cabinet or light cupboard doors. The tracks are precision, aluminium profiles and the concealed bottom rollers have nylon tyres and sealed ball bearings. The system is supplied as a kit finished in a mix of polished chrome and silver anodised aluminium. Glass requires no drilling or preparation apart from a 22mm hole for the handles.



Ideal for: Small glass cabinet, cupboard doors and reception hatches

